

# Boulderboard® 8 Foot training station

The Boulderboard8 is a freestanding training wall designed for climbing-focused and upper body power training. It is attractive, light weight and can be easily disassembled for storage. It can be ordered in a Base version with frame and panels only or the Pro Package that is fully outfitted with a crashpad and 51 training holds. It is used in both residential and commercial training areas. This is the largest Boulderboard we make: for smaller areas see the 4 and 6 foot models.

The Boulderboard 8 fits under an 8-foot (2.44 m) ceiling at its steepest angle of 40 degrees, with an angle extension that allows multiple angles up to 15 degrees with taller ceilings. The unit has a 8x10 foot (2.44 m x 3.1 m) climbing surface equipped with a generous 345 threaded potential hold locations. The top has a sturdy pullup bar for additional training options. The hold pattern can be customized to fit a variety of LED training walls.

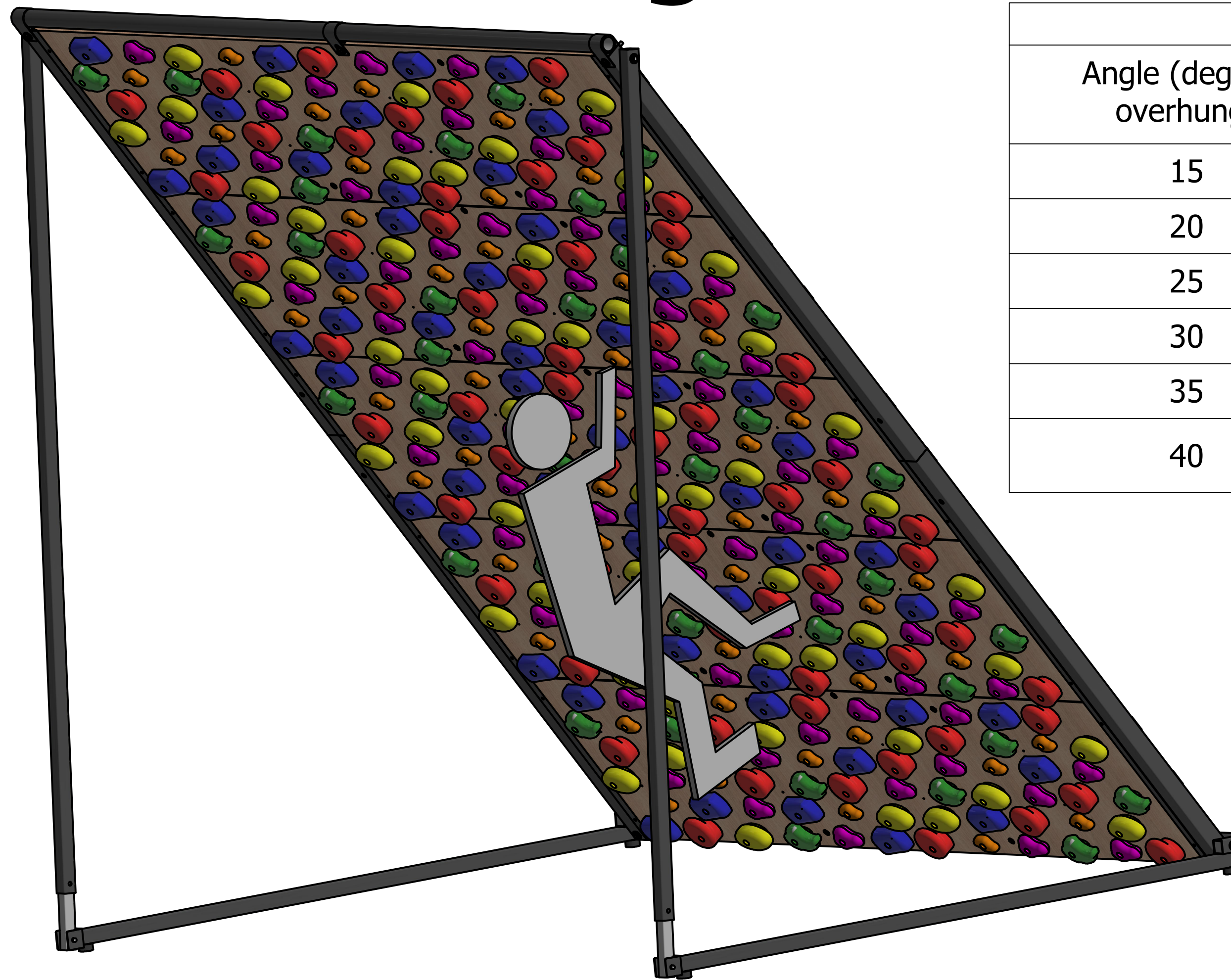

Boulderboard® Angles			
Angle (degrees overhung)	Extender hole	Height (in)	Height (m)
15	5	119.5	3.04
20	4	116	2.95
25	3	112	2.85
30	2	107	2.72
35	1	101.5	2.58
40	No extender	95.5	2.43

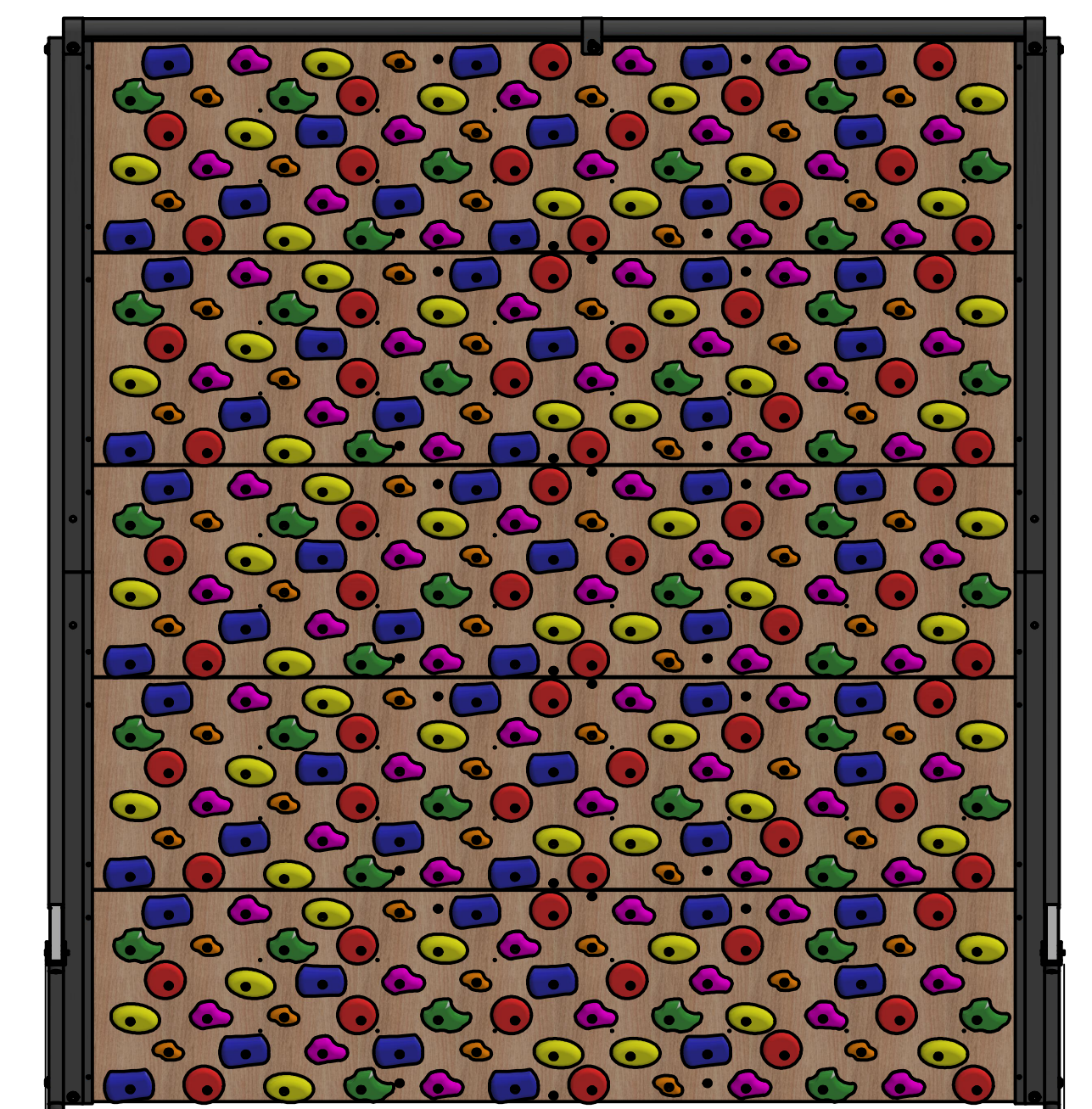

Front View

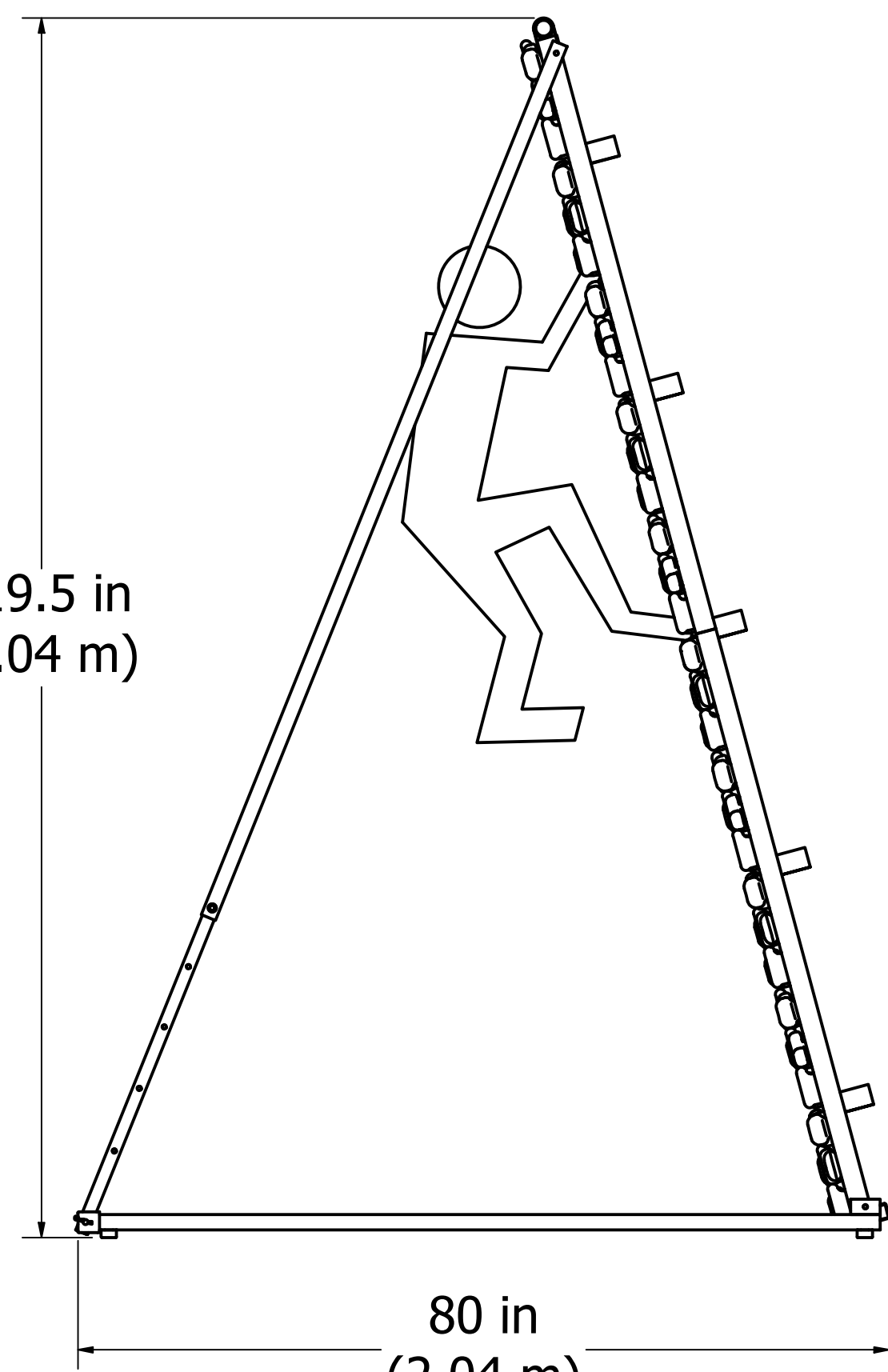

15 degrees overhung

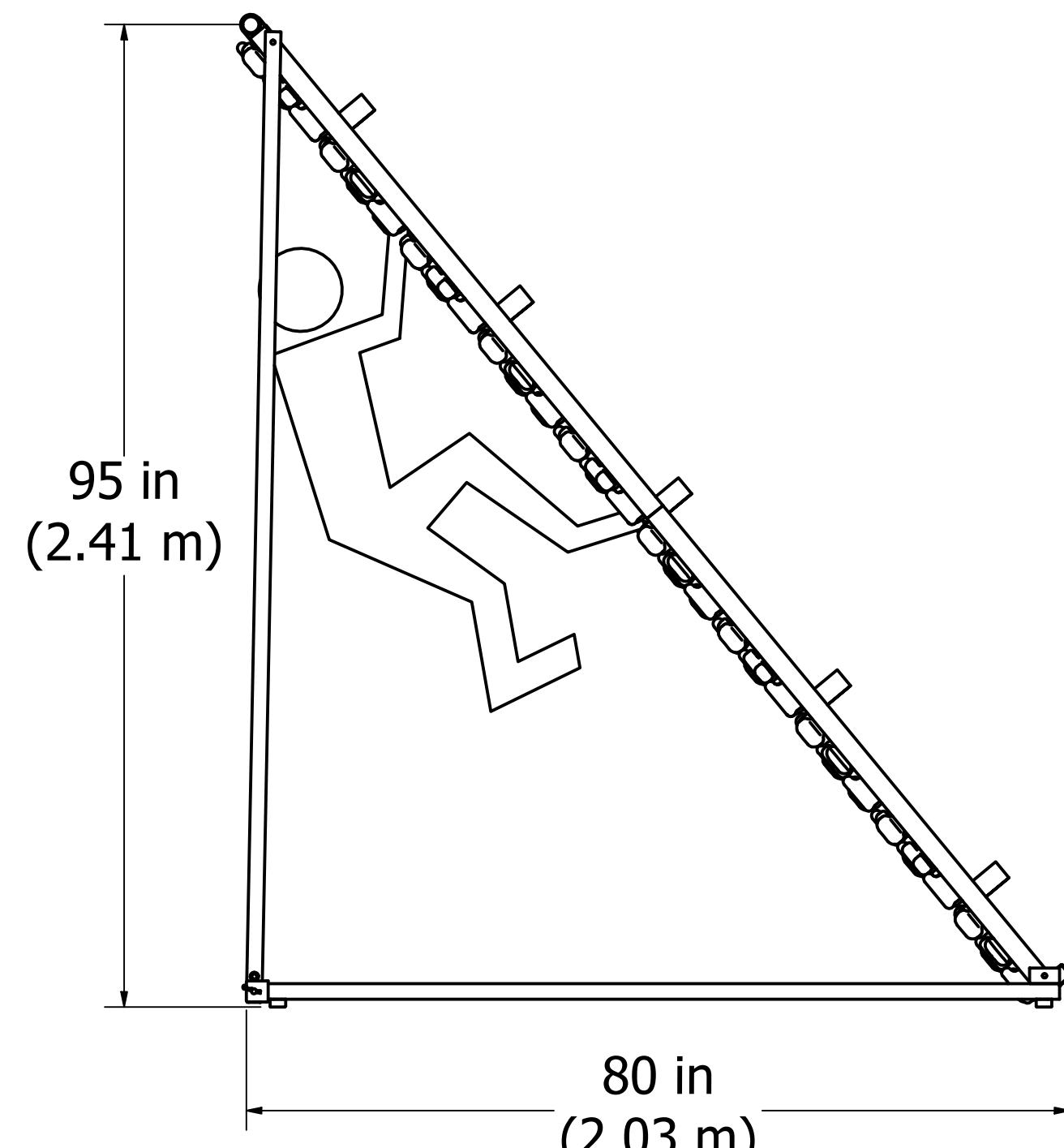

40 degrees overhung

## Specifications:

- Weight: 480 pounds (218 Kg).
- Construction: Steel framework with custom-machined wood panels.
- Placement: Inside standard - outside with exterior upgrade.
- Width of climbing surface: 8 feet (2.44 m).
- Total length of climbing surface: 10 feet (3.1 m).
- Number of possible hold placements: 345.
- T-nuts: 3/8-16 pre-installed.
- Angle: Adjustable.
- Frame color: Anthracite Gray - galvanized (with exterior upgrade).
- Panel color: Natural Wood with water based coating.
- Warranty: 1 year limited warranty.