



Instructions for Boulderboard Extenders

Parts:

- (2) extenders
- (2) 3/8" x 2.25 bolts and hardware

Adding the extenders is best done while the unit is lying on the ground, prior to lifting. However, it can be done anytime with the assistance of 2-3 persons.

1. Remove the plastic caps from the bottom end of the uprights.
2. Using the correct orientation (see image – bottom hole down, four other holes above) and the extender holes aligned with the hole in the upright, insert the extender into the upright.
3. Using the 3/8" x 2.25 bolts provided with the extenders, bolt them into the lowest hole.
4. Lift wall and insert pin into the lower hole.



BoulderBoard

Climbing Trainer

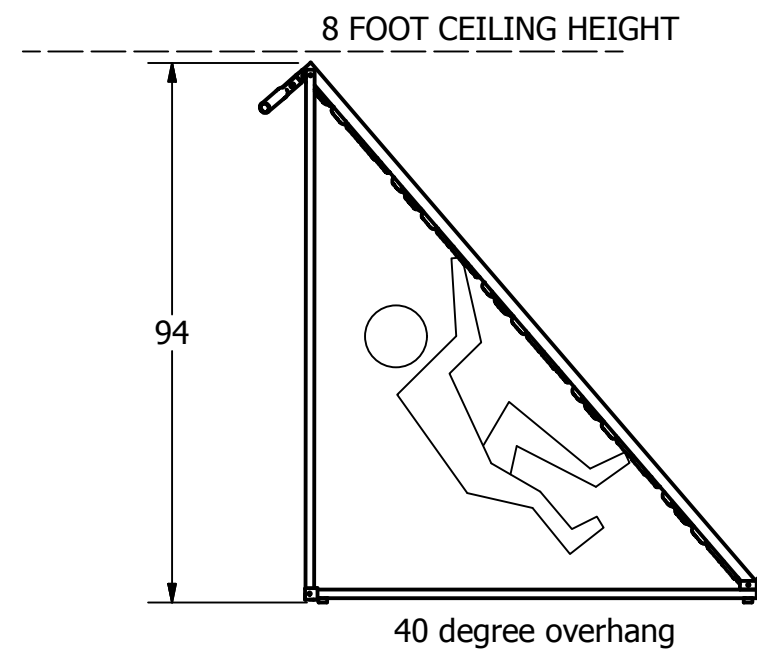

Standard BoulderBoard:

41 degree overhang

Without optional upright extensions the boulderboard is 93" high.
Fits under a standard 8 foot ceiling.

10 FOOT CEILING HEIGHT

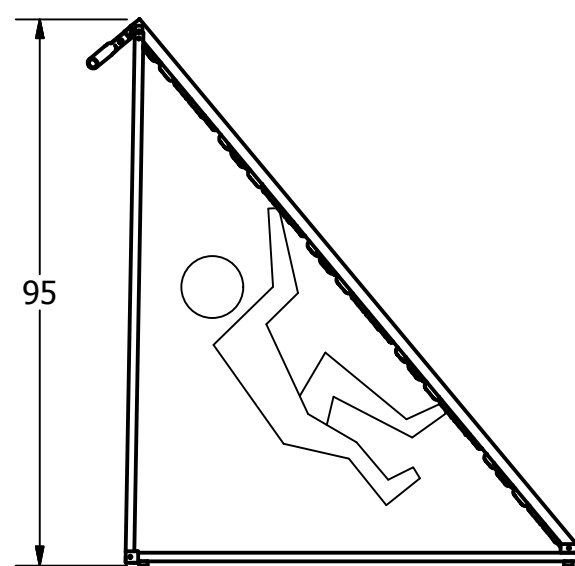

40 degree overhang

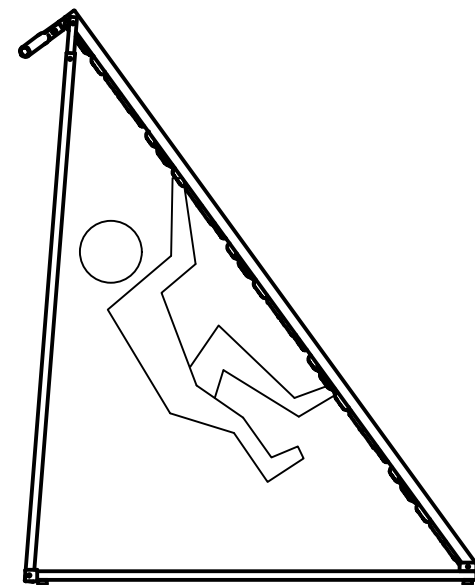

36 degree overhang

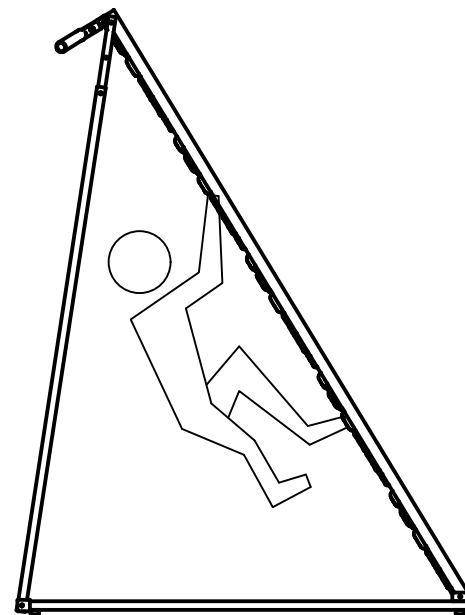

31 degree overhang

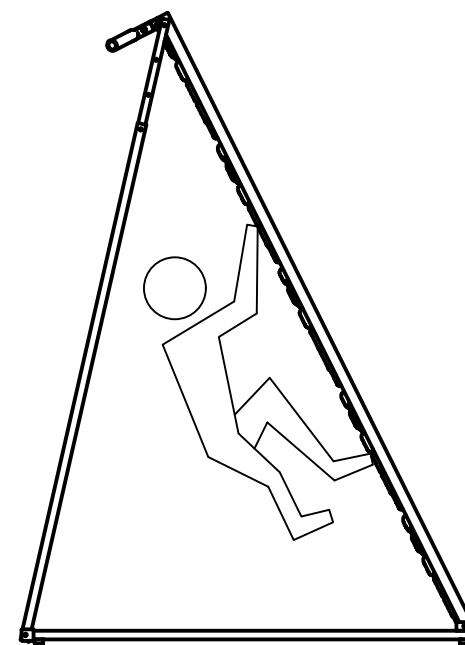

27 degree overhang

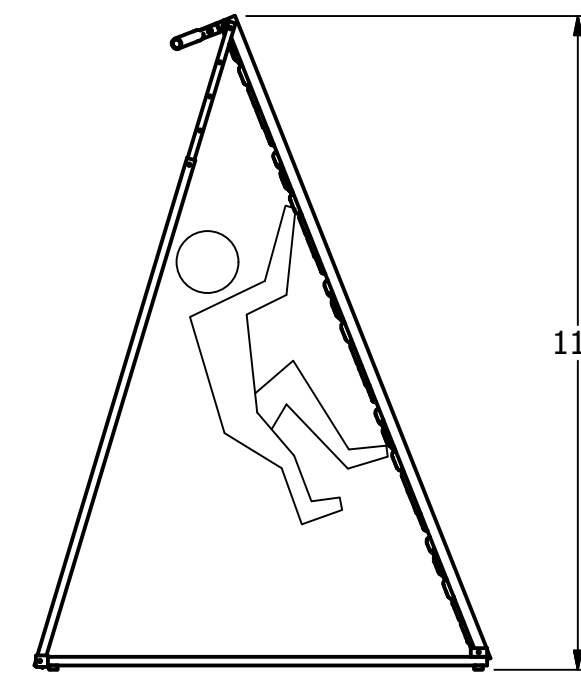

22 degree overhang

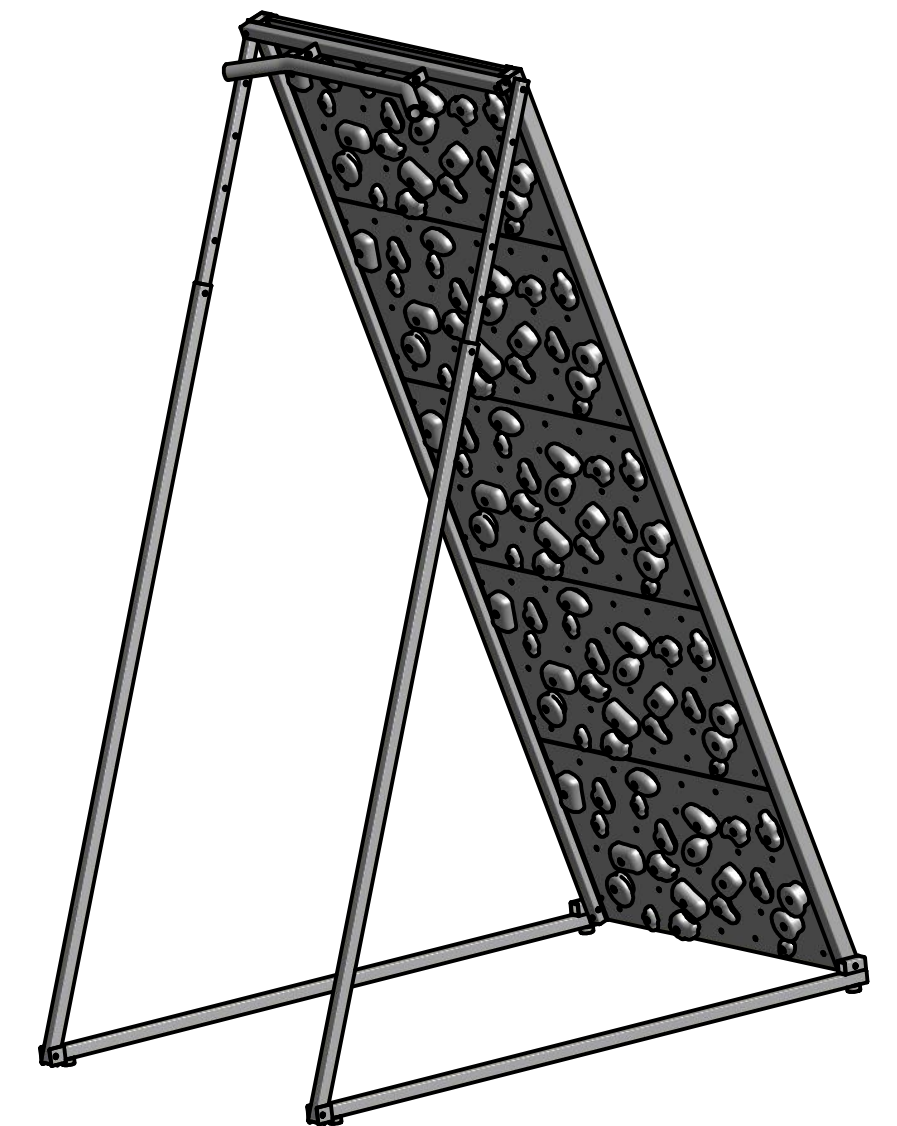

Extended BoulderBoard:

Available angles with optional upright extensions
(Upright extensions are included with Pro model)